

INCORPORATING RISK ASSESSMENT AND INHERENTLY SAFER DESIGN PRACTICES *into Chemical Engineering Education*

JEFFREY R. SEAY

University of Kentucky • Paducah, KY 42002

MARIO R. EDEN

Auburn University • Auburn, AL 36849

Process safety is a fundamental component of sound process design. Although the chemical industry has demonstrated an excellent safety record over the years,^[1] the quantities and hazardous nature of many of the substances typically handled by chemical manufacturers make the potential for large-scale disasters a constant concern. Because safety is so critical in industry, it is vital to introduce the concept of safe process design practices during undergraduate chemical engineering education. From famous historic disasters such as Flixborough and Bhopal to recent events such as the Texas City BP Refinery explosion in 2005, the importance of process safety in chemical process design is abundantly clear. An appreciation of this gained during a chemical engineer's education can only enhance chemical manufacturing safety in the future.

In industry, the concept of process safety is firmly rooted in the concept of risk. From government regulatory requirements, such as those outlined by OSHA and the EPA,^[2-4] to industry initiatives such as Responsible Care, the requirement of quantifying and managing risk is paramount. In addition to working within economic and environmental constraints, the process design engineer is also tasked with reducing the risk of operating a chemical manufacturing process to an acceptable level for employees, regulatory authorities, insurance underwriters, and the community at large. Therefore, a

holistic approach to process safety as an integral component of sound process design is critical.

In addition to the study of toxicological impacts and quantifying release scenarios, an understanding of how risk is quantified in the chemical process industries will allow future process design engineers to mitigate those risks at the earliest



Jeffrey Seay is an assistant professor in the Department of Chemical and Materials Engineering at the University of Kentucky. He recently moved to academia after 12 years in industry. He holds a B.S. (1996) and Ph.D. (2008) from Auburn University, and an M.S. (2004) from the University of South Alabama, all in chemical engineering. In addition to his professional experience as a process design engineer, he is a trained PHA Team Leader with extensive experience in risk assessment methodology and layer-of-protection analysis.

Mario Eden is presently an assistant professor in the Department of Chemical Engineering at Auburn University. He received his M.S. (1999) and Ph.D. (2003) degrees from the Technical University of Denmark. Dr. Eden's work seeks to advance the state of the art in process systems engineering (PSE) research and education through innovative and novel systematic methodologies for integrated process and product design. Dr. Eden is a recipient of the NSF CAREER award (2006).



stage of conceptual process development—the stage where an engineer has the greatest influence on the final process design. This paper will present, by case-study example, how the fundamental concepts of inherently safer process design can be integrated into chemical engineering education.

RISK ASSESSMENT METHODOLOGY

Quantifying Risk

In order to begin understanding the benefits of inherently safer process design, the chemical engineering student must first understand risk. The concept of risk is often misunderstood by both the general public and students of chemical engineering. It is important to separate the concept of risk from the concept of hazard. While the concept of hazard relates to the potential for adverse consequences, risk is rather a combination of both the severity of the consequences of an upset scenario and the likelihood of that scenario's initiating

cause. This is an important distinction. The potential hazard associated with a substance or process is an inherent property that cannot be changed. The risk associated with handling a substance or operating a process can be high or low, depending upon the safeguards included in the design. Thus, for chemical engineers, the most important distinction between hazard and risk is that risk can be reduced through process design.

In order to begin to discuss risk, the process design engineer must first consider potential upset scenarios. In other words, answer the question, "What is the worst thing that can happen?" Answers to this question typically involve loss of containment of a process chemical with causes ranging from failure of control loops and operator errors to external events such as fire, among many others. It is critical to note that the answers to the aforementioned question must be considered independently of the likelihood of the worst-case scenario occurring. Again, it is the combination of both the severity and

the likelihood that determines the risk. In order to ensure a complete and consistent assessment of potential upset scenarios, a structured approach must be applied. The need for such an approach is the basis for a Process Hazard Analysis.

Process Hazard Analysis

A Process Hazard Analysis (PHA) is a methodology for reviewing and assessing the potential hazards of a chemical process by using a structured, facilitated, team brainstorming approach. A PHA is typically facilitated by a trained team leader and attended by a wide variety of plant personnel, including engineers, managers, operators, maintenance technicians and safety, health, and environmental (SHE) personnel. Although several techniques are available for performing PHAs,^[3] the goal of the PHA is always the same

What If...?	Initiating Cause	Consequence	Safeguards
1. There is High Pressure in the Cyclohexane Storage Tank?	1.1 Failure of the pressure regulator on nitrogen supply line to Cyclohexane Storage Tank.	1.1 Potential for pressure in tank to rise due to influx of nitrogen pad gas through failed regulator. Potential to exceed design pressure of storage tank. Potential tank leak or rupture leading to spill of a flammable liquid. Potential fire should an ignition source be present. Potential personnel injury should exposure occur. 2.1 Potential environmental release requiring reporting and remediation.	1. Conservation vent sized to relieve overpressure due to this scenario. 2. Pressure transmitter with high alarm set to indicate high pressure in Cyclohexane Storage Tank

Hazard Scenario	Process Operation	Potential Upset Case	Inherently Safer Design
Overpressure	Filling a process vessel with a pump	Overpressure by pump deadhead due to overfill	1. Vessel design pressure greater than pump deadhead pressure 2. Static head due to vessel elevation plus vessel design pressure greater than pump deadhead pressure.
Overpressure	Operating a vessel under inert gas pressure	Failure of inlet gas regulator leading to overpressure.	1. Vessel design pressure greater than inert gas supply pressure.
Underpressure	Emptying a process vessel with a pump	Blocked vent leading to vessel collapse due to vacuum pulled during pump out.	1. Vessel designed for full vacuum
Underpressure	Draining an elevated process vessel by gravity.	Blocked vent leading to vessel collapse due to vacuum pulled during draining.	1. Vessel designed for full vacuum 2. Liquid drain lined sized to be self-venting.

—to identify the potential hazards of a process and determine whether sufficient safeguards are in place to mitigate those hazards.

CLASSROOM EXAMPLE OF APPLYING PHA METHODOLOGY

The following is a simple example that can be used to illustrate the basic concepts of a PHA in the chemical engineering classroom. Consider a low design pressure API storage tank filled with cyclohexane. API type storage tanks are typically designed for no more than 2.5 pounds of pressure and only a few inches of water of vacuum. Therefore, careful control of pressure is critical. Furthermore, assume that the storage tank is equipped with a “pad/de-pad” vent system to control pressure, and is located in a diked tank farm. Table 1 illustrates a typical scenario that might be developed during a PHA using the “What If...?” methodology.

In **Table 1**, the listed safeguards would be effective means of mitigating the personnel exposure and environmental impact consequences identified for this scenario. In addition to the cause illustrated, other causes of high pressure that might be considered by a PHA Team include the following:

- *External fire in the area, leading to increased vapor pressure in the storage tank.*
- *Overfill via the supply pump, leading to overpressure by deadhead pump pressure.*

If the safeguards identified by the PHA team are not deemed adequate, recommendations are made for the implementation of additional safeguards. This technique, called Layer of Protection Analysis (LOPA), is often employed by PHA teams to quantitatively assess the risk associated with an upset scenario so that appropriate layers of protection can be applied to adequately mitigate the risk.^[5]

Hazard assessment and layer of protection analysis are complex subjects. As such, a formal hazard analysis is typically not performed during the conceptual phase of process design. In most cases, the PHA is performed during

the engineering phases of a project. A basic understanding of the fundamentals of risk assessment, however, is extremely beneficial to the development of inherently safer designs during the conceptual phase of process design. To make inherently safer design choices during conceptual development of a process, the design engineering student must be aware of the types of hazard scenarios that may be identified for each piece of equipment or system.

Inherently Safer Process Design

Inherently safe process design practices can generally be grouped into five categories:^[6, 7]

- *Intensification*
- *Substitution*
- *Attenuation*
- *Limitation of effects*
- *Simplification*

Some examples of inherently safer design choices for typical process applications are included in **Table 2**.

Typically, however, these types of design choices are made in later stages of engineering development. Although these are important design considerations, it is very beneficial to begin evaluating inherently safer design strategies at the earliest stages of process development, when the process design engineer has the greatest opportunity to affect the safety

Process Design Choice	Inherently Safe Design Category	Potential Process Safety Impact
Reactor type	Intensification	Continuous reactors are typically smaller than batch reactors for a given production volume.
Feed stocks	Substitution	Less hazardous raw materials may be available to make the same products.
Process solvents	Substitution	Less hazardous and/or less volatile solvents may be available.
Reaction mechanism	Attenuation	Endothermic reactions present less potential for runaway.
Operating conditions	Attenuation	Temperatures and pressure close to ambient are typically less hazardous.
Process utilities	Attenuation	Low pressure utilities such as hot oil may be a safer choice than high pressure steam.
Alternative technology	Attenuation	Use of alternative technology, for example pervaporation instead of azeotropic distillation using a solvent entrainer.
Production rate	Limitation of effects	A continuous process making just what is required can be safer than a batch process with a large hold-up volume.
Storage volume	Limitation of effects	Minimization of volume limits the potential effects of a release.
Equipment layout	Simplification	Utilizing gravity flow minimizes the need for rotating equipment.
Cooling by natural convection	Simplification	Utilizing natural convection simplifies the process and eliminates the potential for process upsets due to loss of utilities.

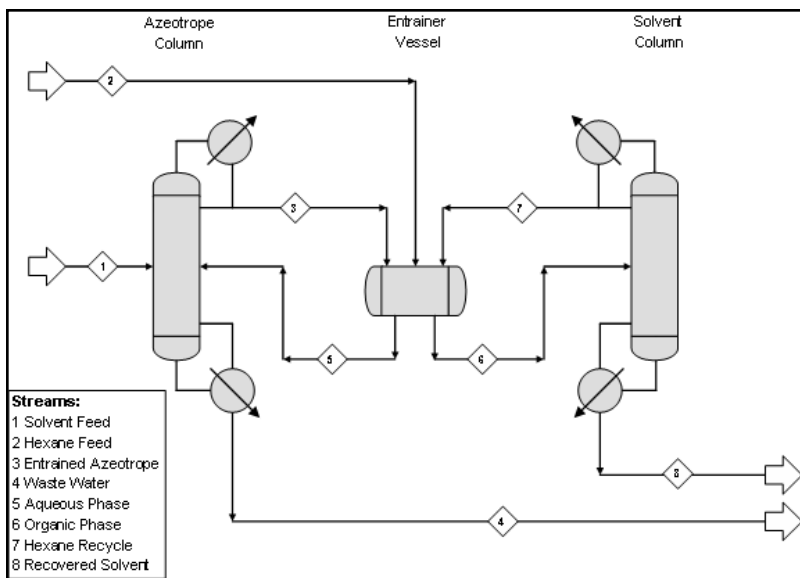

Figure 1. Flow diagram of traditional solvent recovery process.

aspects of the process. Some examples of design choices that are typically made at the onset of conceptual engineering are illustrated in Table 3 (previous page).

Initially, inherently safer designs may seem to be more expensive than applying traditional safeguards to processes. When the total cost of the process is considered, however, the inherently safer design is often more cost effective. Installing and maintaining multiple independent layers of protection can be quite expensive, but these costs are often ignored during initial cost estimates. Conceptual phase cost estimates are usually based on stand-alone major equipment costs that are simply multiplied by factors to obtain the total installed cost. These factors are intended to account for instrumentation and controls, among other items needed for the complete process installation. To apply the same factors to traditional and inherently safer processes, however, can lead to an erroneous comparison and conclusion. Inherently safer processes will typically require fewer safety controls, which leads to lower installation and operating costs. These factors should be considered when evaluating processes during a hierarchical approach to process design. Additional cost savings for inherently safer processes that are often overlooked include insurance costs and costs associated with regulatory compliance.

Case Study—Solvent Recovery

The following case study is presented as a classroom engineering design problem to illustrate the techniques of applying inherently safer design choices.

Consider a chemical process using 1-propanol as a solvent. Currently, the waste solvent ends up as a waste-water stream for disposal. The task

for the process design engineer is to develop a process to recover the 1-propanol from the waste-water stream. This separation is complicated by the fact that water and 1-propanol form a minimum-boiling azeotrope. Therefore, separation by ordinary distillation is not possible.

Traditional Process

The traditional method employed for breaking this azeotrope uses a third solvent, or entrainer. For the water/1-propanol system, cyclohexane works well for the separation. A sample flow diagram of the azeotropic distillation process is given in Figure 1.

In this process, the minimum-boiling azeotrope is separated from the water in the Azeotrope Column and is collected as an overhead product. The azeotrope is then mixed with the cyclohexane in the Entrainer Vessel. The 1-propanol is soluble in cyclohexane, while the water is not. The water phase, with a small amount of 1-propanol, is then recycled back to the Azeotrope Column, while the cyclohexane/1-propanol mixture is fed to the Solvent Column, where 1-propanol is recovered as a bottoms product and the cyclohexane—with a small amount of 1-propanol—is recycled to the Entrainer Vessel. This simple system is easily modeled using any process simulation software package.

Potential Upset Scenarios

From a process design perspective, this process is certainly acceptable. From the perspective of safety, however, some significant concerns arise. In order to break the azeotrope, a highly volatile solvent, cyclohexane, is introduced to the process. A sample of some of the potential hazard scenarios that might be generated during a PHA is illustrated in Table 4.

Some potential safeguards that might be used to mitigate these hazards include safety relief valves, redundant in-

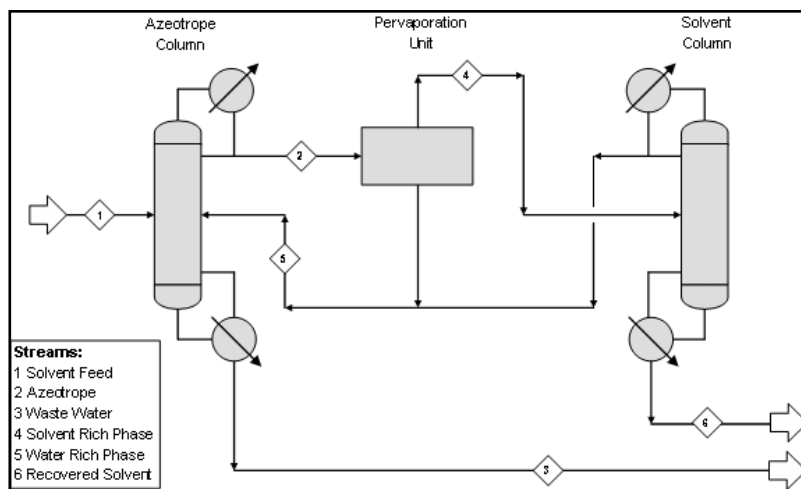

Figure 2. Flow diagram of inherently safer solvent recovery process.

strumentation, and hardwired interlocks independent from the primary basic process control system (BPCS). All of these safeguards would be applied to the process during later stages of process design, as considering inherently safer design choices could make such safeguards unnecessary.

An Inherently Safer Process

An inherently safer approach to this design problem will include technology to break the azeotrope without introducing additional, flammable solvents to the process. One possible solution is the use of a pervaporation membrane. A pervaporation membrane separates two liquids by partial vaporization through a nonporous membrane, such as ceramic. The pervaporation membrane is able to break azeotropes due to its ability to separate components based on polarity differences between the molecules, rather than relying on differences in vapor pressure, like distillation does.

Although the pervaporation technology could be used to completely separate 1-propanol from the water in one step, such a sharp split would most likely prove to be prohibitively expensive. An optimum design using a combination of distillation and pervaporation can be achieved, as illustrated in [Figure 2](#).

In this design, the azeotrope is again separated from the water as an overhead product in the Azeotrope Column, but in this process, instead of using an entrainer, the Pervaporation Unit is used to separate the liquids. Because this technology is used in conjunction with distillation, a sharp split is not needed. The water-rich phase leaving the Pervaporation Unit is returned to the Azeotrope Column, and the 1-propanol is recovered as a bottoms product from the Solvent Column, with the azeotrope being collected overhead and returned to

What If...?	Initiating Cause	Consequence
1. There is higher pressure in the Entrainment Vessel?	1.1 External fire in the process area.	1.1 Potential increased temperature and pressure leading to possible vessel leak or rupture. Potential release of flammable material to the atmosphere. Potential personnel injury due to exposure.
	1.2 Pressure regulator for inert gas pad fails open.	1.2 Potential for vessel pressure to increase up to the inert gas supply pressure. Potential vessel leak or rupture leading to release of flammable material to the atmosphere. Potential personnel injury due to exposure.
2. There is higher level in the Entrainer Vessel?	2.1 Vessel level transmitter fails and indicates lower than actual volume.	2.1 Potential to overflow vessel with cyclohexane. Potential to flood vent line with liquid leading to flammable liquid reaching the vent gas incinerator. Potential to overwhelm incinerator leading to possible explosion. Potential personnel injury due to exposure.

the Azeotrope column. This design is advantageous because it can be optimized to minimize the impact of the cost of the Pervaporation Unit.

Process Safety Improvements

The inherently safer design has the obvious advantage of having eliminated the flammable solvent, cyclohexane, from the process. Taking a wider view, not only is the cyclohexane eliminated from the process itself, but also from storage areas, unloading areas, and waste treatment. In addition to the benefit of eliminating a flammable solvent from the process, the Pervaporation Unit minimizes the circulating flow of material through the system. Therefore, the column and associated heat exchangers are smaller than with the traditional process design. Based on the hazard scenarios identified for the traditional process, illustrated in [Table 4](#), the benefits of the inherently safer process are illustrated in [Table 5](#).

From this assessment, the benefits of the inherently safer process are clear. The pervaporation process addresses three of the five categories of inherently safer design choices: Attenuation, Simplification, and Limitation of Effects. Attenuation is due to the use of alternative technology, Simplification is due to the elimination of the entrainment solvent from the process, and Limitation of Effects is due to the smaller equipment and chemical inventories. Of course, 1-propanol is a flammable liquid, so all of the upset scenarios listed in [Table 4](#) would still need to be considered, but by eliminating the cyclohexane from the process, the overall severity of the consequences would be reduced. Since, as discussed previously, risk is a combination of both severity and likelihood, the overall risk of the inher-

Upset Scenario	Traditional Process	Inherently Safer Process
External Fire	Large volume of flammable liquid circulating in process.	Flammable volume limited to recovered solvent only.
Overflow	Cyclohexane entrainer more volatile than 1-propanol.	Minimal liquid hold up in Pervaporation Unit.
Overpressure	Larger liquid hold-up leads to higher severity in the event of a release.	Volume limited to solvent distillation hold-up.

ently safer design would be reduced. Although a more in-depth study would be required before making the choice of which solvent recovery process is preferred, it should be clear that these decisions must be made in the early stages of conceptual process development in order to benefit the process.

CONCLUSIONS

One of the responsibilities of every chemical engineer is to ensure that the excellent safety record enjoyed by the chemical process industry is maintained. Therefore it is important to begin introducing the fundamentals of process safety during undergraduate chemical engineering education. The purpose of this work has been to underscore, by case-study example, the natural relationship between inherently safe process design and conceptual process development, and describe how it can be integrated into undergraduate process design education. As has been illustrated by this case study, taking a holistic approach to process safety education can serve to reinforce the benefits of beginning to consider the safety implications of the decisions made during conceptual process development. By reinforcing the benefits of making inherently safe design choices during conceptual process development, students

of process engineering will be better prepared for the challenges of meeting the high standards of safety set by today's chemical industry.

ACKNOWLEDGMENTS

The authors would like to acknowledge Felicia Foster and Robert D'Alessandro of Evonik Degussa Corporation for providing valuable insight and guidance on the industrial applications of process safety.

REFERENCES

1. Sanders, R., *Chemical Process Safety – Learning from Case Histories*, 3rd Ed., Elsevier, Inc., (2005)
2. Nelson, D., *Managing Chemical Safety*, Government Institutes, (2003)
3. Environmental Protection Agency, "Process Hazard Analysis," 40 CFR 68.67 (2005)
4. Occupational Safety and Health Administration, "Process Safety Management of Highly Hazardous Chemicals," 29 CFR 1910.119 (2005)
5. Center for Chemical Process Safety, *Layer of Protection Analysis – Simplified Process Risk Assessment*, AIChE (2001)
6. Kletz, T., *Process Plants: A Handbook for Inherently Safety Design*, Taylor and Francis (1998)
7. Center for Chemical Process Safety, *Guidelines for Engineering Design for Process Safety*, AIChE, 1993. □