

USING THE EVOLUTIONARY OPERATION METHOD

To Optimize Gas Absorber Operation (A Statistical Method for Process Improvement)

JIMMY L. SMART

University of Kentucky • Paducah, KY 42002

Evolutionary Operation (EVOP) is a statistical tool developed for incrementally moving the operation of a dynamic process in the direction of some optimum set of conditions. The EVOP method^[1] was introduced in the late 1950s as a field application technique for improving existing industrial processes. It was to be applied to an existing manufacturing process that was currently producing acceptable product. By exploring small incremental changes in an existing set of process conditions, the process could be improved and moved in the direction of some process optimum.

There are other advanced statistical methods, such as strategies of experimentation,^[2] simplex optimization,^[3] response surface methodology,^[4] and advanced factorial design,^[5] but they are more complex and require a great deal of training for reliable application and interpretation. Most of the methods deal with an initial strategy of experimentation when formulating a set of bench-scale experimental runs. The goal of experimental design is to minimize the number of runs while at the same time maximizing the amount of useful information.

MOTIVATION

EVOP is a simple technique that is relatively easy to apply and provides intuitive, yet statistically based results. In the chemical engineering undergraduate laboratory at the University of Kentucky, students operate a carbon dioxide scrubber to gain training in using the EVOP method. Not only do they acquire knowledge of how to design a scrubber, but they also learn how the interplay of various operating parameters affects the overall scrubbing performance of the device. Details of this student experience were previously delivered at

the annual ASEE conference in 2003.^[6]

Typically, a gas scrubber is a packed column that uses liquid media such as water to absorb and remove contaminants from polluted industrial gas streams. This scrubbing process often serves as a final process step prior to release of the “clean” air into the environment. Chemical engineering students in the undergraduate curriculum learn to design packed columns for use as air pollution control devices. Most curricula include some hands-on training with these devices in the laboratory environment. The design techniques learned by students are approximate methods based on such operating variables as column-pressure drop, packing factors, and mass transfer coefficients. These approximations often serve as a fundamental basis for design and construction of air pollution control devices, but in reality, final optimization and fine-tuning are often performed by engineers in the field on already-installed operational equipment. The EVOP technique is ideally suited for optimizing existing equipment operation. In addition to EVOP, some investigators have successfully applied other advanced statistical methods to the dynamic optimization of a packed gas absorber.^[7]

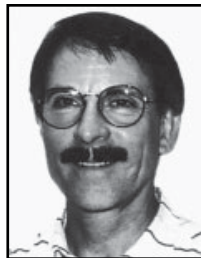

Jimmy Smart is Associate Professor of Chemical and Materials Engineering at the University of Kentucky. He received his BS chemical engineering degree from Texas A&M and his MS and PhD from the University of Texas at Austin, all in chemical engineering. He has over 20 years industrial experience with companies such as IBM and Ashland Chemical. His research areas include applications of membranes to purify water supplies and treatment of hazardous wastes.

The purpose of this laboratory exercise is to introduce students to the use and application of the EVOP method. . . . Not only do they acquire knowledge of how to design a scrubber, but they also learn how the interplay of various operating parameters affects the overall scrubbing performance of the device.

The purpose of this laboratory exercise is to introduce students to the use and application of the EVOP method. Using sodium hydroxide solutions to scrub CO₂ emissions is not commonly found in industry—aqueous solutions of potassium hydroxide or amines, in conjunction with arsenite catalysts, are usually more desirable from an economic standpoint.^[8] Sodium hydroxide solutions were selected for this exercise, however, because of their ready availability in educational laboratories.

In this exercise, students are presented with a packed scrubber that is currently being used to remove CO₂ from a simulated industrial stack gas. Gas flow rate, CO₂ inlet concentration, and column diameter are fixed operational parameters. Existing conditions include use of once-through ambient water flowing countercurrent to the gas flow in a column packed with spherical packing material. Students use principles of EVOP to optimize column performance by selecting appropriate column packing, liquid recirculation rate, caustic concentration, and temperature. Column performance in this exercise is defined as lowest CO₂ emission, not lowest cost.

EVOP METHOD

Since EVOP's introduction in the late 1950s, many books and journal articles have been published discussing the method. This article is not intended as a survey review of EVOP; the reader is invited to consult the original publication or other excellent discussions^[9-12] for detailed information and its applications. The purpose of this article is to introduce undergraduate students in the chemical engineering laboratory curriculum to EVOP and to provide a procedure and list of equipment for faculty who might wish to set up a similar experiment. This introductory EVOP exercise provides a basis for further study leading to response surface theory and culminating in contemporary quality strategies in a manufacturing plant environment, such as Total Quality Management^[13] and Six Sigma.^[14]

In a research laboratory environment, strict requirements for formulating strategies of experiments can usually be satisfied. Usually, all independent and dependent variables can either be measured or carefully controlled. Principles behind orthogonal design, generation of response surfaces, randomization, experimental replication, and factorial designs can be successfully met. In a manufacturing plant environment, however, there are forces at work not subject to

control by operating personnel, including economic factors, product demands, and other undefined influences. Quite often, orthogonal designs are not compatible with production requirements.

EVOP is a procedure designed to meet the needed flexibilities inherent to the plant environment. It should be emphasized that EVOP is a routine method for permanent process operation, not an experimental procedure. It is to be applied in an existing plant operation rather than used at the pilot/laboratory scale. It was developed to avoid undesirable characteristics of full-scale process experiments that require specially trained personnel and the subsequent production of off-specification product. EVOP requires no special staff and can be used by existing plant operators after a brief training period.

Plant operators find EVOP appealing because of its intuitive approach. EVOP philosophy says to explore the effects of process variables near current operating conditions and make adjustments that will drive the process in a direction that offers improvement, whether it be quality, reduced cost, greater output, or less waste. Another added bonus behind implementation of EVOP is that it improves overall understanding of the process itself. Plant personnel gain a better understanding of the effects of process variables upon product quality. Also, subtle effects are often discovered that were not previously known to exist.

IMPLEMENTATION

The basic idea behind using EVOP is to improve the signal-to-noise ratio of an existing process in an effort to uncover relationships between operating variables. The signal is *increased* by deliberately introducing carefully chosen minor variations about an existing operational point, called the "works process." Noise within the process arises from a variety of sources, such as variability of raw materials, inability to precisely control process inputs, and instrument and measurement error. The final variation in the product yield is a composite of all these sources. The magnitude of the variation is measured by the standard deviation.

The first step in implementing EVOP is to identify pertinent process variables associated with an existing process. Then, a cycle of process runs is designed around the normal or existing values of the process variables. We deliberately introduce small changes in the process signal or process out-

puts and investigate their effects. Differences between normal and proposed values are kept necessarily small to avoid production of off-specification product. Generally, it is impractical to investigate the effects of more than three variables in an industrial process, so a 2^3 factorial design is arranged. It investigates the effects (response) of low and high levels of three process variables. Cycles of runs are repeated to replicate operational conditions and to reduce experimental error. Here, we reduce the noise level in the process by repeatedly measuring the process output at a fixed set of operating conditions.

Assume a 2^3 factorial design is set up around our first phase (ambient temperature), where the variables to be studied are recirculation rate, caustic concentration, and packing material. A "phase" is defined as a set of variables to be tested, and it forms the cubic geometry of the 2^3 factorial design, as shown in Figure 1. One complete "cycle" is defined as a complete collection of process runs from point 1 to point 8 of the cube (phase). Anywhere from three to six cycles are run for each phase to provide a valid statistical analysis. The output response to be optimized is the % CO_2 concentration in the stack gas. From Table 1, the experimental runs are set up to explore the low and high variations of these variables and the output responses for each set of conditions are noted at each apex of the cube shown in Figure 1.

Once a factorial design is arranged, it is normal statistical practice to randomize the order of the runs within each cycle. Randomization ensures that if systematic trends occur from untested variables, these effects will not be mistaken for effects from deliberately introduced changes in tested variables. Randomization also validates our analysis that assumes that errors within cycles are independent of each other. In an actual plant manufacturing environment, it is difficult to organize a random-run sequence, but by following different run sequences over the course of various cycles, randomization is assured.

After four cycles are completed for phase one, the results are averaged for each variable effect (actual results are shown in Table 1). The main effects and interaction between effects are determined from using the averages at each apex of the cube shown in Figure 1.

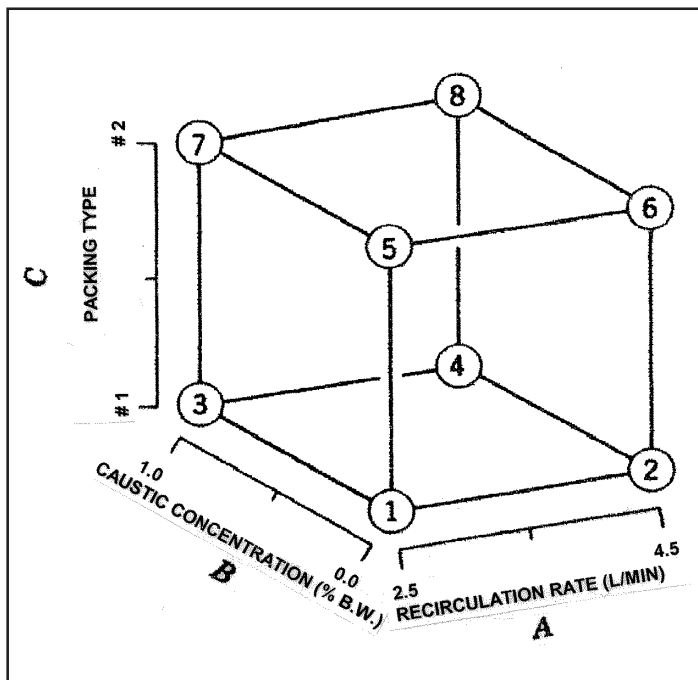

Figure 1. 2^3 factorial design for phase one.

TABLE 1
Eight Sets of Conditions of a 2^3 Factorial Design
(Phase 1 containing 4 cycles)

Run	A Recirculation Rate/ L/min	B Caustic Concentration % by wt	C Packing Type	Average CO_2 in Stack Gas % by volume
1	2.5	0.0	#1	9.87
2	4.5	0.0	#1	8.97
3	2.5	1.0	#1	7.45
4	4.5	1.0	#1	7.28
5	2.5	0.0	#2	9.90
6	4.5	0.0	#2	9.93
7	2.5	1.0	#2	6.10
8	4.5	1.0	#2	5.18

TABLE 2
Analysis of Main Effects and Interactions

	mean	std. dev.	A recirc/ temp	B caustic	C packing	AB	AC	BC	ABC	\pm S.E.
Phase 1	8.09	1.77	-0.49	-3.17	-0.62	-0.06	0.05	-1.11	-0.42	± 1.25
Phase 2	4.64	1.53	-3.31	-2.11	1.56	-0.33	-0.60	-0.26	-0.23	± 1.08

Main effects are calculated as

$$\begin{aligned} A &= \frac{1}{4}(\bar{y}_2 + \bar{y}_4 + \bar{y}_6 + \bar{y}_8) - \frac{1}{4}(\bar{y}_1 + \bar{y}_3 + \bar{y}_5 + \bar{y}_7) \\ B &= \frac{1}{4}(\bar{y}_3 + \bar{y}_4 + \bar{y}_7 + \bar{y}_8) - \frac{1}{4}(\bar{y}_1 + \bar{y}_2 + \bar{y}_5 + \bar{y}_6) \\ C &= \frac{1}{4}(\bar{y}_5 + \bar{y}_6 + \bar{y}_7 + \bar{y}_8) - \frac{1}{4}(\bar{y}_1 + \bar{y}_2 + \bar{y}_3 + \bar{y}_4) \end{aligned} \quad (1)$$

Two-factor interactions are calculated as

$$\begin{aligned} AB &= \frac{1}{4}(\bar{y}_1 + \bar{y}_4 + \bar{y}_5 + \bar{y}_8) - \frac{1}{4}(\bar{y}_2 + \bar{y}_3 + \bar{y}_6 + \bar{y}_7) \\ AC &= \frac{1}{4}(\bar{y}_1 + \bar{y}_3 + \bar{y}_6 + \bar{y}_8) - \frac{1}{4}(\bar{y}_2 + \bar{y}_4 + \bar{y}_5 + \bar{y}_7) \\ BC &= \frac{1}{4}(\bar{y}_1 + \bar{y}_2 + \bar{y}_7 + \bar{y}_8) - \frac{1}{4}(\bar{y}_3 + \bar{y}_4 + \bar{y}_5 + \bar{y}_6) \end{aligned} \quad (2)$$

Three-factor interaction is calculated as

$$ABC = \frac{1}{4}(\bar{y}_2 + \bar{y}_3 + \bar{y}_5 + \bar{y}_8) - \frac{1}{4}(\bar{y}_1 + \bar{y}_4 + \bar{y}_6 + \bar{y}_7) \quad (3)$$

Results from these calculations are summarized in Table 2. A negative sign on the main effect or interaction is desirable in this exercise because it indicates a reduction in %

CO₂ stack gas emissions.

After main effects and interactions have been tabulated, we must use a statistical tool to help us decide what variable effect is significant, *i.e.*, what response is above the “noise level” of the process. Traditional statistical tests are not appropriate in assessing the uncertainties associated with EVOP because of the small number of observations. Instead, the most practical way to evaluate EVOP uncertainty has been found to be the use of two standard-error limits. A standard error (S.E.) is the estimated standard deviation of the variable of interest. If the true standard deviation, σ , of the process variable was known, ± 2 S.E. limits would represent approximately a 95% confidence limit. The *true* standard deviation is not known, but an estimate of the standard deviation, s , can be calculated. We use this estimate to formulate our ± 2 S.E. limits to guide us in interpreting what effects and interactions are significant. Variances and standard errors can be calculated from Table 3.¹¹ An estimate of the true variance, σ^2 , is calculated as

$$s^2 = \frac{\sum_{i=1}^n (y_i - \bar{y})^2}{n - 1} \quad (4)$$

where s^2 is an estimate of the true variance, y_i is an individual observation, \bar{y} is the mean, and n is the total number of ob-

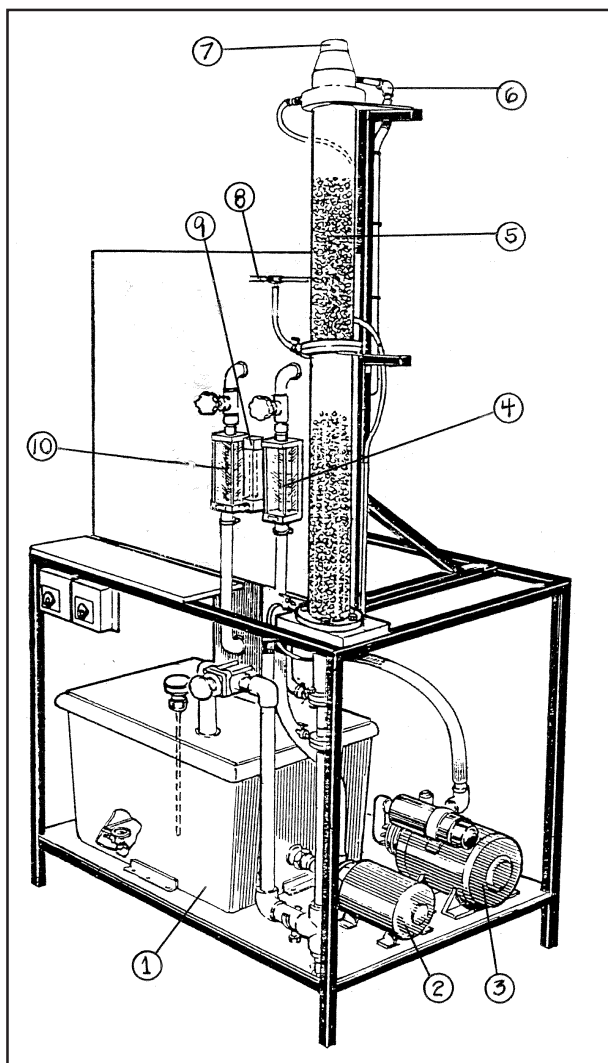

Figure 2.

Gas Absorption Column

Legend:

1. Recirculation sump (40-L capacity)
2. Liquid recirculation pump
3. Air blower
4. Rotameter for recirculated liquid (1-10 L/min)
5. Packing material (clear plastic column)
6. Scrubber liquor inlet
7. Scrubber discharge stack (gas outlet)
8. Pressure taps for checking Δp across the packed column
9. Rotameter for CO₂ (0-20 L/min)
10. Rotameter for air (20-180 L/min)

TABLE 3
Variances (σ^2) and Standard Errors for Main Effects and Interactions Estimated from a 2^p Factorial Design after c Cycles with Estimate of the Standard Deviation, s .

Design	2^p	2^2	2^3
Variance	$4\sigma^2/c2^p$	σ^2/c	$\sigma^2/2c$
Standard Error	$2s/(c2^p)^{1/2}$	$s/c^{1/2}$	$s/(2c)^{1/2}$

servations. An estimate of the true standard deviation is just $\sqrt{s^2}$. For a 2^3 factorial design, the standard error of effects is calculated as $s/\sqrt{2c}$. Therefore, the 2 S.E. limits for the effects in our design are provided by

$$\text{effect} \pm 2 \left(\frac{s}{\sqrt{2c}} \right) \quad (5)$$

Final calculated results for standard error limits are shown in Table 2. Data collected from phase two of this exercise where temperature, caustic concentration, and packing material were evaluated, are shown in Table 4.

NOTE: In the interest of reducing student laboratory time to a reasonable period, the EVOP method in this laboratory exercise has not been strictly followed in that

- Larger ranges of temperature ($\pm 13^\circ\text{C}$) were selected to clearly demonstrate their effect on scrubbing efficiency. In a plant environment, smaller temperature ranges ($\pm 5^\circ\text{C}$) would probably be selected for each factorial design (phase). Remember that one of the advantages of the EVOP method is the generation of minimal quantities of off-spec product.
- In a plant environment, four cycles would typically be used to average the output response. Instead of cycling through all eight apexes of the factorial cube before beginning the second cycle, four distinct samples for each given set of experimental conditions were collected.
- The run order was not strictly followed. For example, in phase one, in order to delay use of caustic, we followed the run order of 1-2-5-6-3-4-7-8.

EXPERIMENTAL SET-UP

An existing experimental laboratory scrubber package by Armfield, Ltd., (see Figure 2) was modified for this exercise. The column is made of clear plastic with dimensions of 9 cm OD by 1.7 m tall. The overall column consists of two packed

sections, each having a packed bed depth of 55 cm and one liquid redistributor. Three types of packing were offered to students for optimization purposes: 1/2" (1.3 cm) diameter polypropylene balls, 3/8" (1 cm) glass Pall rings, and 3/16" (0.5 cm) Jaeger stainless steel slotted rings (see Figure 3 and Table 5).

During operation of the scrubber, CO_2 is supplied from a standard gas cylinder, regulated through a rotameter, and mixed with air from an air blower to provide a 10% by volume mixture of CO_2 in air (compare this to CO_2 emissions from coal-fired power plants that are typically 14%). This gas mixture is routed to the bottom of the packed column and allowed to flow upward through the column. Scrubber liquor enters the top of the column and flows downward through the packed bed where it acts to absorb (scrub) CO_2 from the gas stream. "Clean" gas exits through the top of the scrubber. The purpose of this exercise is to find the combination of operating parameters to minimize the percent CO_2 leaving the scrubber stack.

An inexpensive (\$350) Bacharach Fyrite[®] gas analyzer was

TABLE 4
Eight Sets of Conditions of a 2^3 Factorial Design
(Phase 2 containing 4 cycles)

Run	A Temperature °C	B Caustic Concentration % by wt	C Packing Type	\bar{y} , Avg. CO_2 in Stack Gas % by volume
1	12	1.0	#2	5.05
2	38	1.0	#2	4.53
3	12	2.0	#2	3.30
4	38	2.0	#2	2.58
5	12	1.0	#3	7.25
6	38	1.0	#3	5.98
7	12	2.0	#3	5.43
8	38	2.0	#3	3.05

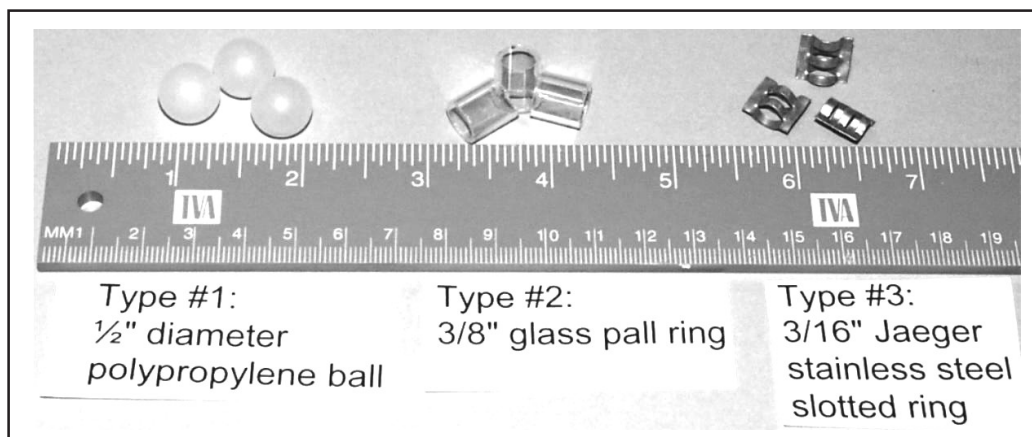

Figure 3. Random packing used for scrubber internals.

used to measure CO₂ concentrations in air for both scrubber inlet and exit. Other, more expensive, gas analyzers and analytical equipment provide greater accuracy, but ±0.1 vol % was adequate for the purposes of this exercise. Precision, or repeatability, under experimental conditions proved to be ±8%. The Fyrite provides a quick and easy method for measurement of CO₂ in air. It employs the Orsat method of volumetric analysis involving chemical absorption of carbon dioxide into a potassium hydroxide solution. A rubber bulb is used to draw the gas sample into the indicator solution. The instrument is inverted and the percentage of gas absorbed by the Fyrite fluid is immediately read from the scale (0-20%). Temperature of the scrubber recirculation sump was controlled by a bath circulator (NESLAB Instruments, RTE-100) fitted with an external cooling coil.

Teams of three to five students can be formed to complete this exercise. Safety procedures should include familiarity with the NaOH Material Safety Data Sheet (MSDS) and Fyrite device, location of the eyewash/shower, and wearing appropriate personal protective equipment (PPE) for handling caus-

TABLE 5
Properties of Random Packing

Packing Type	Packing pieces/cm ³	Surface area/vol Δp/L (cm water/cm ² /cm ³)@ 2.5 ml liquid/min	Pressure drop:
#1: 1/2"-diameter P/P sphere	4.2	21.3	0.16
#2: 3/8" glass Pall ring	5.5	35.2	0.06
#3: 3/16: Jaeger s.s. slotted ring	18.1	49.0	0.05

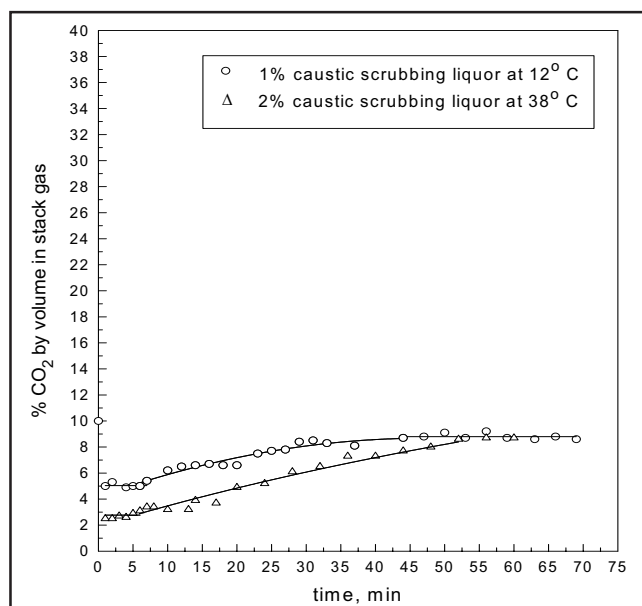

Figure 4. Unsteady-state nature of scrubber performance: recirc rate, 4.5 L/min, #2 packing (lines added to guide the eye).

tic. The first set of data (varying concentration at ambient temperature) can be collected in one afternoon, but the more lengthy elevated/reduced temperature settings require completion on subsequent days.

After students become familiar with the equipment and have characterized existing scrubber performance, they are ready to apply the EVOP method. A 2³ factorial experimental matrix is set up to measure the response (level of CO₂ emissions) from small changes in operating variables (liquid flow rate, caustic concentration, and temperature). Standard error limits are tabulated to build response surfaces to judge positive and negative effects of parameter changes for a given packing material. Results from these small changes are used to guide the students in making judgments as to what direction parameters should be adjusted to achieve a final process optimum.

The final submitted report should include safety and operational procedures, collected data, calculations, results, sources of experimental error, and a discussion that includes which direction the final process optimum will lie and how to proceed to locate this optimum.

DISCUSSION

In actual scrubbers at industrial power plants, Ca(OH)₂, called slaked lime, is used to remove the hazardous air pollutant, sulfur dioxide, from stack gases. In this experiment, another strong base, NaOH, is used to remove CO₂ from our simulated stack gas. The primary reactions that occur during the scrubbing process are

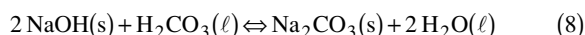
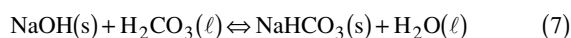
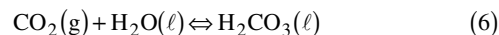

In Eq. (6), a weak dibasic acid, carbonic acid, is formed when carbon dioxide is mixed with water. As the caustic solution (a strong base) contacts the carbonic acid, either sodium bicarbonate is formed from Eq. (7) or sodium carbonate from Eq. (8). The reactions can be found as titration curves in any standard analytical chemistry text^[15] and can be monitored in the scrubber with a pH probe.

In the absorption process, the overall rate is governed by diffusion and chemical reactions occurring in the liquid phase. The reaction is a pseudo first-order reaction between dissolved CO₂ and OH⁻ in the liquid and is of the same order of magnitude as the rate of diffusion.^[16]

For an industrial scrubber, a tank supplying scrubber medium typically contains several thousand gallons. Unfortunately, the working volume of the small recirculation sump in our experimental apparatus is only about 38 L. Based on an assumption of plug flow at a recirculation rate of 4.5 L/min, where the pump suction and recirculated liquor return

are located at opposite ends of the sump, a working time of only 8.5 minutes is available. The unsteady-state nature of the scrubbing action is charted in Figure 4. Sure enough, for about 8 minutes, the percent CO_2 by volume in air is 5.0. After this period, the percent CO_2 slowly climbs to a steady-state value of 8.8 after 44 minutes. During the initial 8 minutes, the sodium carbonate salt (Eq.8) is probably being formed. After the initial period there are probably equilibrium competitions between Eqs. (7) and (8), until a steady-state condition is attained.

As previously mentioned, repeatability of experimental measurements with the gas analyzer was $\pm 8\%$. This value would be viewed as high in a laboratory setting, but is probably a realistic value in a plant environment. The lack of repeatability was not due to the instrument itself, but was primarily due to gas-flow drifting fluctuations in the rotameter, Joule-Thompson effects of gas expansion across the CO_2 cylinder regulator, and observed channeling effects of liquid flow in the packed column.

RESULTS

The main effects and interactions between process variables are summarized in Table 2. In phase 1, recirculation rate (A), % caustic (B), and packing material (C) were evaluated. From consideration of each effect ± 2 S.E., it appears the increase of caustic from 0% to 1% had a strong negative effect (decreasing the percent of CO_2 in the stack gas, which is a desirable outcome). The other effects are not significant since they are below the error limits and can be considered to be within the noise of the process. One surprising result is the fact that the main effect (A) of the recirculation rate was not significant. There was no advantage to increasing the recirculation rate from 2.5 to 4.5 L/min. Evidently, the scrubbing effect is not diffusion-rate limited, but reaction-rate limited.

In phase 2 of Table 2, the temperature (A), % caustic (B), and packing material (C) were evaluated. From consideration of each effect ± 2 S.E., it appears only the main effects of temperature (A), % caustic (B), and packing material (C) were significant. The result of increasing the temperature and % caustic had a strong negative effect (decreasing the % CO_2 in the stack gas). On the other hand, switching the packing from Pall rings to more open stainless steel slotted rings had a strong positive effect (increasing the % CO_2 in the stack gas). This is a somewhat surprising result, since the slotted rings offer more surface area/volume and less pressure drop (see Table 5). This can be explained (as was shown from results of phase 1) by the fact that the scrubbing effect is limited by reaction rate, not the diffusion rate. The slotted rings offer more open geometry (less Δp) and therefore less liquid holdup within the packed beds. With glass Pall rings, there is more liquid holdup within the column, which favors reaction between CO_2 to form the carbonates. In the case of packing #1 (P/P spheres), this geometry offers a much reduced surface area/volume,

which lowers the reaction rate between the gas and liquid phases within the column.

CONCLUSIONS

From this abbreviated application of EVOP, we can draw some conclusions as to what direction the optimum for this scrubbing process might lie. The optimum will reside in a direction of elevated operating temperature and higher % caustic in the scrubbing liquor. Packing material #2 (Pall rings) is more desirable in decreasing the overall % CO_2 in the stack gas, but is just slightly out of the error limits. In the final analysis, packing #3 (slotted rings) may be a more favorable choice because of the lower operating cost (less Δp /length of packing height).

From the EVOP analysis, use of higher % caustic reduced CO_2 emissions from our scrubber stack. Where might the overall process optimum reside? From the MSDS, sodium bicarbonate is soluble in water to about 8% b.w. at 18°C. Therefore, this condition would be the limiting factor on what maximum concentration of NaOH to use in the scrubbing liquor. Anything above about 8% to 10% would cause salting-out of solids that would foul and possibly occlude scrubber packing. It is interesting to compare the main effect of % caustic for phase 1 and phase 2. Moving from 0% caustic to 1% had a very strong negative effect (CO_2 reduced in stack gas), whereas moving from 1% to 2% had a less strong negative effect. The response surface is not linear. This situation calls for additional investigation, as a process optimum may reside somewhere between 2% caustic and the recommended maximum limit of 10% caustic. Other investigators⁽¹⁷⁾ have found the optimum mass transfer coefficient to reside at a 2M NaOH solution (about 8% b.w.).

Where might the elevated process optimum temperature lie? A cost analysis would have to be performed on a better-defined response surface to identify optimum temperature. In a plant environment, unless low-pressure waste steam is available, the energy costs to heat the scrubber liquor is probably not justified. One point to consider, however, is that usually inlet stack gases fed to scrubbers (especially those from power plants) are often at elevated temperatures. Another alternative is to add 50% b.w. caustic with enough water in a mixing tee to form a 10% b.w. caustic solution just prior to its introduction to the scrubber. This method would allow some elevation of temperature due to heat of solution.

This exercise has been prepared to provide an undergraduate student with experience in the use and application of the EVOP method in a laboratory environment. As demonstrated, the student can set up additional variable ranges to be tested for phases 3 and 4, and so forth, to identify a final optimization of the overall scrubbing process.

REFERENCES

1. Box, G., and N.R. Draper, *Evolutionary Operation*, John Wiley & Sons,

- New York, NY (1969)
2. Box, G.E.P., W.G. Hunter, and J.S. Hunter, *Statistics for Experimenters*, John Wiley & Sons, New York, NY (1978)
 3. Walters, F.H., S.L. Morgan, L.R. Parker, and S.N. Deming, *Sequential Simplex Optimization*, CRC Press, Boca Raton, FL (1991)
 4. Montgomery, D.C., *Design and Analysis of Experiments*, John Wiley & Sons, New York, NY (2001)
 5. Box, G., W.G. Hunter, and J.S. Hunter, *Statistics for Experimenters*, John Wiley & Sons, New York, NY (1978)
 6. Smart, Jimmy L., "Use of an Applied Statistical Method to Optimize Efficiency of an Air Pollution Scrubber Within an Undergraduate Laboratory," *ASEE Conf. Proc.*, Nashville, TN, June (2003)
 7. Hoerner, G.M., and W.E. Shiesser, "Simultaneous Optimization and Transient Response Evaluation of Packed-Tower Gas Absorption," *Chem. Eng. Prog. Symp. Ser.*, **61**(55), p. 115 (1965)
 8. Danckwerts, P.V., and M.M. Sharma, "The Absorption of Carbon Dioxide into Solutions of Alkalis and Amines," *The Chem. Engr.*, p. 244, October (1966)
 9. Klingel, A.R., and R.G. McIntyre, "An Experimental Strategy for Investigating Commercial Processes," *Appl. Statistics*, **11**(2), p. 79, June (1962)
 10. Spendley, W., G.R. Hext, and F.R. Himesworth, "Sequential Application of Simplex Designs in Optimisation and Evolutionary Operation," *Technometrics*, **4**(4), p. 441, November (1962)
 11. Carpenter, B.H., and H.C. Sweeny, "Process Improvement with Simplex Self-Directing Evolutionary Operation," *Chem. Engr.*, p. 117, July 5 (1965)
 12. Scarrah, W.P., "Improve Production Efficiency via Evolutionary Operation," *Chem. Engr.*, p. 131, December 7 (1987)
 13. Schmidt, S.R., M.J. Kiemele, and R.J. Berdine, *Knowledge-Based Management*, Air Academy Press, Colorado Springs, CO (1997)
 14. Breyfogle, F.W., *Implementing Six Sigma: Smarter Solutions Using Statistical Methods*, John Wiley & Sons, New York, NY (1999)
 15. Fritz, J.S., and G.H. Schenk, *Quantitative Analytical Chemistry*, 4th ed., Allyn & Bacon, Boston, MA, p. 184 (1979)
 16. Sherwood, T.K., and R.L. Pigford, *Absorption and Extraction*, McGraw-Hill, New York, NY, p. 358 (1952)
 17. Tepe, J.B., and B.F. Dodge, *Trans. Am. Inst. Chem. Engrs.*, **39** (1943) □

Book Review: *Discussion of the Method*

Continued from page 203.

did not wish to appeal to Greek authority. Readers must either accept Koen's synopsis of such major thinkers as Kant, Gödel, and Wittgenstein, or they must be conversant with the history of Western thought, principally in philosophy. This requires either an abstraction of the thinkers cited, or many years of reading.

William Perry^[2] suggested that the intellectual development of college students consists of stages that progress from authoritarian dualism (Stages 1 through 3) through the slough of relativism (Stages 4 through 6) to committed action (Stages 7 through 9), and indicated that relativism is where many college students get stuck. The relative equality of opinion and the absence of authority lead to the lack of commitment that is sometimes predominant in education today.

As applied to pedagogy, Koen's book also suggests that a departure from authority (dualism) is good, but going beyond relativism is better. Koen's method for doing so is through heuristics. Heuristics, or general rules-of-thumb, are particularly important guides in the absence of absolutes.

Koen's book provides some guidance in dealing with ambivalence of contrasting heuristics, often incorporated in society's aphorisms. How does one balance the contrasting heuristics of "Look before you leap," with "He who hesitates is lost"? It is clear that the triage advice, "When you hear hoofbeats, think horses not zebras," has a geographic limitation—it applies more in the Western world than Africa. According to Koen, contradictions require judgment to obtain a basis for action, to get beyond relativism.

In the score of years since its original publication, Koen's ASEE book has been used in a freshman honors seminar "Paradoxes of the Human Condition," with between 12 and

15 students per year, in an effort to find a way beyond Relativism in the Absolute versus Relative paradox. One week the students discuss the Absolute through Descartes' effort to break from Greek authority. The following week the students discuss Koen's *Definition of the Engineering Method* in parallel with Perry's model of intellectual development.

Our students' essays indicate that a study of Koen's heuristics initiates progress away from a Relativistic position. In other words, even though an absolute is not known, heuristics show the way to take appropriate action, or to choose between two actions. As such, the students readily embrace Koen's perspective of heuristics, and their combination into a state-of-the-art, or paradigm.

Professor Koen's book suggests a startling, explicit statement of a new way to think about engineering and life, but a method which may already be implicit in the subconscious of most practicing engineers. If we, as educators, wish to prepare our students for engineering practice, the techniques indicated in this book provide a philosophical underpinning for dealing with risks associated with engineering actions and designs, when there is insufficient applicable science. The interesting extension of Koen's engineering philosophy to life is, at a minimum, worthy of our consideration.

REFERENCES

1. Bloom, B.S., *Taxonomy of Educational Objectives. Handbook I. Cognitive Domain*, Addison-Wesley Publishing Co. (1984)
2. Perry, William O., *Intellectual and Ethical Development in the College Years: A Scheme*, Holt, Rinehart & Winston, New York (1968) □